

# Faswerkzeuge, Ø 19 – Ø 71 mm

Chamfering tools

Outils de chanfreinage

Ersatzteile und Abdeckplatte ①  
ab Seite D 7.1.  
Allgemeines Zubehör und Bedienschlüssel siehe Kapitel Z, Zubehör.

Spare parts and cover plates ① from page D 7.3. General accessories and service keys, see chapter Z, Accessories.

Pièces de rechange et caches de protection ① de la page D 7.1. Accessoires généraux et clés de service chapitre Z Accessoires.

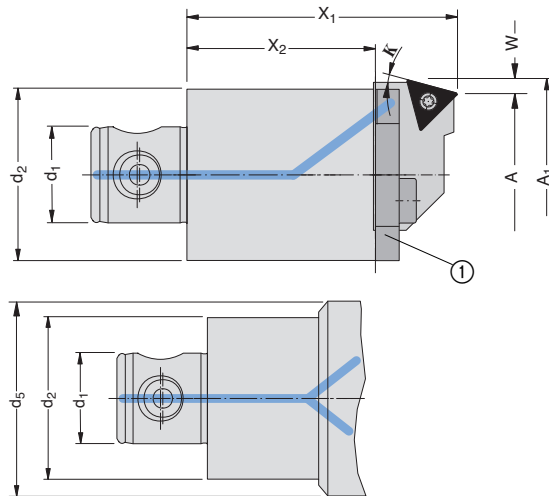
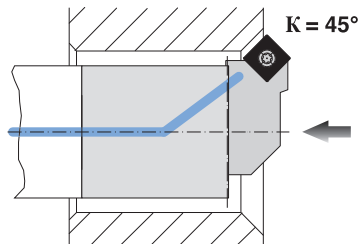

MVS-  
Verbindungs-  
stelle  
MVS  
connection  
Connexion  
MVS

Einstell-  
winkel  
Approach  
angle  
Angle  
d'attaque

Boh-  
rungs-Ø  
Bore  
range  
Plage Ø  
alésage

Anfas-Ø  
Chamfer  
range  
Plage Ø  
chan-  
freinage

Kerzbahn-  
körper  
Serrated tool  
body  
Corps cranté

Wende-  
schneid-  
platten-Form  
Insert form  
Forme  
de plaquette

Platten-  
halter  
Insert holder  
Porte-  
plaquette

Best.-Nr.  
Order No.  
No de cde.

Best.-Nr.  
Order No.  
No de cde.

d <sub>2</sub>	d <sub>1</sub>	K	A	A <sub>1</sub>	X <sub>1</sub>	X <sub>2</sub>	d <sub>5</sub>	W	kg	Best.-Nr. Order No. No de cde.	Best.-Nr. Order No. No de cde.	
25 - 14		15°	24 - 32	29 - 37	60	42	-	2,5	0,2	148 001	161	201 057
25 - 14		15°	31 - 39	36 - 44	60	42	30	2,5	0,2	148 002	161	201 058
25 - 14		20°	22 - 30	29 - 37	60	42	-	3,5	0,2	148 001	161	201 017
25 - 14		20°	29 - 37	36 - 44	60	42	30	3,5	0,2	148 002	161	201 018
25 - 14		30°	20 - 28	29 - 37	60	42	-	3,5	0,2	148 001	161	201 067
25 - 14		30°	27 - 35	36 - 44	60	42	30	3,5	0,2	148 002	161	201 068
25 - 14		45°	19 - 27	29 - 37	58	42	-	5,0	0,2	148 001	111	201 005
25 - 14		45°	26 - 34	36 - 44	58	42	-	5,0	0,2	148 001	111	201 006
25 - 14		45°	31 - 39	43 - 51	60	42	30	6,0	0,2	148 002	112	201 007
32 - 18		15°	31 - 39	36 - 44	60	42	30	2,5	0,2	148 017	161	201 058
32 - 18		20°	29 - 37	36 - 44	60	42	30	3,5	0,2	148 017	161	201 018
32 - 18		30°	27 - 35	36 - 44	60	42	30	3,5	0,2	148 017	161	201 068
32 - 18		45°	31 - 39	43 - 51	60	42	30	6,0	0,2	148 017	112	201 007
32 - 18		15°	35 - 46	43 - 54	71	46	36	4,0	0,4	148 003	163	201 059
32 - 18		20°	33 - 44	43 - 54	71	46	36	5,0	0,4	148 003	163	201 019
32 - 18		30°	28 - 39	43 - 54	71	46	36	5,0	0,4	148 003	163	201 069
32 - 18		45°	35 - 46	50 - 61	66	46	36	7,5	0,4	148 003	113	201 008
40 - 22		15°	35 - 46	43 - 54	71	46	36	4,0	0,4	148 018	163	201 059
40 - 22		20°	33 - 44	43 - 54	71	46	36	5,0	0,4	148 018	163	201 019
40 - 22		30°	28 - 39	43 - 54	71	46	36	5,0	0,4	148 018	163	201 069
40 - 22		45°	35 - 46	50 - 61	66	46	36	7,5	0,4	148 018	113	201 008
40 - 22		15°	37 - 50	45 - 58	80	55	-	4,0	0,7	148 004	163	201 060
40 - 22		20°	37 - 50	47 - 60	80	55	-	5,0	0,7	148 004	163	201 020
40 - 22		30°	37 - 50	52 - 65	80	55	-	5,0	0,7	148 004	163	201 070
40 - 22		45°	43 - 56	58 - 71	80	55	-	7,5	0,7	148 004	113	201 009

K 45°: Anfasen Front- und Rückseite  
Front and reverse side chamfering  
Chanfreinage frontal et sur partie arrière

# Faswerkzeuge, Ø 50 – Ø 216 mm

Chamfering tools

Outils de chanfreinage

Ersatzteile und Abdeckplatte ①  
ab Seite D 7.1.

Allgemeines Zubehör und Bedienschlüssel siehe Kapitel Z, Zubehör.

Spare parts and cover plates ① from page D 7.3. General accessories and service keys, see chapter Z, Accessories.

Pièces de rechange et caches de protection ① de la page D 7.1. Accessoires généraux et clés de service chapitre Z Accessoires.

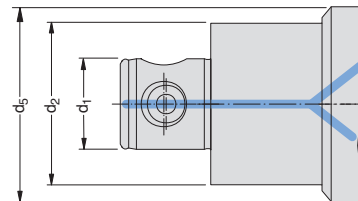
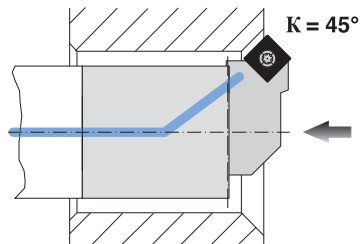

D

MVS- Verbindungs- stelle	Einstell- winkel Approach MVS connection Connexion MVS	Boh- rungs-Ø Bore range Plage Ø alésage	Anfas-Ø Chamfer range Plage Ø chan- freinage								Kerzbahn- körper Serrated tool body Corps cranté	Wende- schneid- platten-Form Insert form Forme de plaquette	Platten- halter Insert holder Porte- plaquette
d <sub>2</sub>	d <sub>1</sub>	K	A	A <sub>1</sub>	X <sub>1</sub>	X <sub>2</sub>	d <sub>5</sub>	W	kg	Best.-Nr. Order No. No de cde.		Best.-Nr. Order No. No de cde.	
50 - 28	15°	50 - 68	58 - 76	80	55	-	4,0	1,0	1,0	148 005	163	201 061	
50 - 28	20°	50 - 68	60 - 78	80	55	-	5,0	1,0	1,0	148 005	163	201 021	
50 - 28	30°	50 - 68	65 - 83	80	55	-	5,0	1,0	1,0	148 005	163	201 071	
50 - 28	45°	55 - 73	70 - 88	80	55	-	7,5	1,0	1,0	148 005	113	201 010	
63 - 36	15°	68 - 89	76 - 97	90	60	-	4,0	1,9	1,9	148 006	163	201 062	
63 - 36	20°	68 - 89	78 - 99	90	60	-	5,0	1,9	1,9	148 006	163	201 022	
63 - 36	30°	68 - 89	83 - 104	90	60	-	5,0	1,9	1,9	148 006	163	201 072	
63 - 36	45°	72 - 93	87 - 108	90	60	-	7,5	1,9	1,9	148 006	113	201 011	
80 - 36	15°	89 - 119	97 - 127	90	60	-	4,0	2,6	2,6	148 007	163	201 063	
80 - 36	15°	119 - 149	127 - 159	90	60	-	4,0	2,7	2,7	148 007	163	201 064	
80 - 36	15°	144 - 199	152 - 207	90	60	125	4,0	3,6	3,6	148 009	163	201 064	
80 - 36	20°	89 - 119	99 - 129	90	60	-	5,0	2,6	2,6	148 007	163	201 023	
80 - 36	20°	119 - 149	129 - 159	90	60	-	5,0	2,7	2,7	148 007	163	201 024	
80 - 36	20°	144 - 199	154 - 209	90	60	125	5,0	3,6	3,6	148 009	163	201 024	
80 - 36	30°	89 - 119	104 - 134	90	60	-	5,0	2,6	2,6	148 007	163	201 073	
80 - 36	30°	119 - 149	134 - 164	90	60	-	5,0	2,7	2,7	148 007	163	201 074	
80 - 36	30°	144 - 199	159 - 214	90	60	125	5,0	3,6	3,6	148 009	163	201 074	
80 - 36	45°	92 - 122	107 - 137	90	60	-	7,5	2,6	2,6	148 007	113	201 012	
80 - 36	45°	121 - 151	136 - 166	90	60	-	7,5	2,7	2,7	148 007	113	201 013	
80 - 36	45°	146 - 201	161 - 216	90	60	125	7,5	3,6	3,6	148 009	113	201 013	

**K 45°: Anfasen Front- und Rückseite**  
Front and reverse side chamfering  
Chanfreinage frontal et sur partie arrière

# Faswerkzeuge, Ø 89 – Ø 216 mm

Chamfering tools

Outils de chanfreinage

**ALU LINE**

Ersatzteile und Abdeckplatte ① ab Seite D 7.1. Allgemeines Zubehör und Bedienschlüssel siehe Kapitel Z, Zubehör.

Spare parts and cover plates ① from page D 7.3. General accessories and service keys, see chapter Z, Accessories.

Pièces de rechange et caches de protection ① de la page D 7.1. Accessoires généraux et clés de service chapitre Z Accessoires.

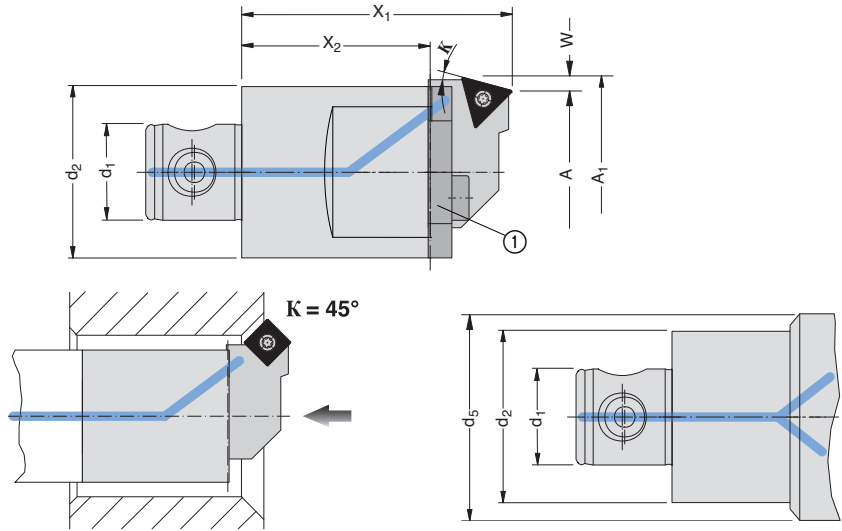

**Anfasen Front- und Rückseite**  
Front and reverse side chamfering  
Chanfreinage frontal et sur partie arrière

MVS-Verbindungsstelle	Einstellwinkel	Bohrungs-Ø	Anfas-Ø	Kerzbahnkörper	Wendeschneidplatten-Form	Plattenhalter
MVS connection	Approach angle	Bore range	Chamfer range	Serrated tool body	Insert form	Insert holder
Connexion MVS	Angle d'attaque	Plage Ø alésage	Plage Ø chanfreinage	Corps cranté	Forme de plaquette	Porte-plaquette

d <sub>2</sub>	d <sub>1</sub>	K	A	A <sub>1</sub>	X <sub>1</sub>	X <sub>2</sub>	d <sub>5</sub>	W	kg	Best.-Nr.	Best.-Nr.
										Order No.	Order No.
										No de cde.	No de cde.
80	36	15°	89 - 119	97 - 127	90	60	-	4,0	1,3	348 007	201 063
80	36	15°	119 - 149	127 - 159	90	60	-	4,0	1,4	348 007	201 064
80	36	15°	144 - 199	152 - 207	90	60	125	4,0	1,8	348 009	201 064
80	36	20°	89 - 119	99 - 129	90	60	-	5,0	1,3	348 007	201 023
80	36	20°	119 - 149	129 - 159	90	60	-	5,0	1,4	348 007	201 024
80	36	20°	144 - 199	154 - 209	90	60	125	5,0	1,8	348 009	201 024
80	36	30°	89 - 119	104 - 134	90	60	-	5,0	1,3	348 007	201 073
80	36	30°	119 - 149	134 - 164	90	60	-	5,0	1,4	348 007	201 074
80	36	30°	144 - 199	159 - 214	90	60	125	5,0	1,8	348 009	201 074
80	36	45°	92 - 122	107 - 137	90	60	-	7,5	1,3	348 007	201 012
80	36	45°	121 - 151	136 - 166	90	60	-	7,5	1,4	348 007	201 013
80	36	45°	146 - 201	161 - 216	90	60	125	7,5	1,8	348 009	201 013

# Faswerkzeuge, Ø 20 – Ø 45 mm

Chamfering tools

Outils de chanfreinage

Allgemeines Zubehör und Bedienschlüssel siehe Kapitel Z, Zubehör.

General accessories and service keys, see chapter Z, Accessories.

Accessoires généraux et clés de service chapitre Z Accessoires.

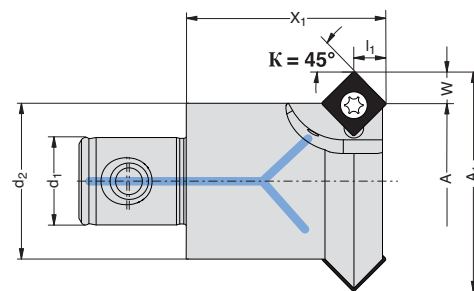
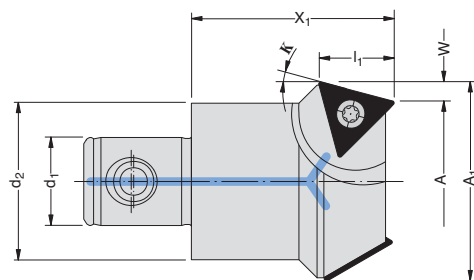

MVS-Verbindungsstelle MVS connection Connexion MVS	Einstellwinkel Approach angle Angle d'attaque	Bohrungs-Ø Bore range Plage Ø alésage	Anfas-Ø Chamfer range Plage Ø chanfreinage						Anzahl Schneiden Number of inserts Nombre de plaquettes	Wende- schneid- platten- Form Insert form Forme de plaquette	Best.-Nr. Order No. No de cde.
d <sub>2</sub>   d <sub>1</sub>	K	A	A <sub>1</sub>	X <sub>1</sub>	l <sub>1</sub>	W	kg	Z			
25 - 14	15°	25	33	31	14	4	0,15	2	64	201 085	
25 - 14	45°	20	33	31	6	6	0,15	2	112	201 082	
32 - 18	15°	32	40	41	14	4	0,20	2	64	201 086	
32 - 18	30°	25	41	41	12	8	0,20	2	64	201 084	
32 - 18	45°	32	45	41	6	6	0,20	3	112	201 083	